

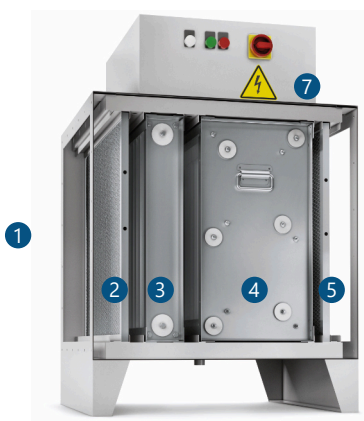

The B 2200 EFM and B 3500 EFM series are the basic element for modular filter solutions in heavy duty design for high particle loads. The connection of a modular filter system unit to the ducting system and the design of the fan unit(s) are highly flexible and are always customer requirement matching. For even higher separation performance due to extreme particle loads, all modular filter units are also available as a tandem version (2 stage design) or as an electrostatic filter unit in combination with a mechanical filter.

Ideal for air handling systems in the field of ventilation and air-conditioning technology. For energy-efficient and high-performance air filtrations of volumes from 2000 m<sup>3</sup>/h and above.



// Principle and equipment example of an electrostatic filter unit

**B 3500 EF M (example)**

horizontal air direction left to right

- 1 Air inlet, 2 pre-filter stainless steel mesh,
- 3 ionizer cell, 4 collector cell,
- 5 post-filter stainless steel mesh, 6 air outlet,
- 7 control unit (flexible placement)

	Air Volume max. m <sup>3</sup> /h	Filter Surface m <sup>2</sup>	Dimensions L/B/H* mm	Weight Kg (ca.)	Module Anz. H x B
B 2200 EFM	2200	15	750 x 400 x 710	80	1 x 1
B 4400 EFM	4400	30	750 x 800 x 710	160	1 x 2
B 6600 EFM	6600	45	750 x 1200 x 710	240	1 x 3
B 8800 EFM	8800	60	750 x 800 x 1420	320	2 x 2
B 3500 EFM	3500	26	750 x 620 x 710	100	1 x 1
B 7000 EFM	7000	52	750 x 1240 x 710 750 x 620 x 1420	200	1 x 2 2 x 1
B 10500 EFM	10500	78	750 x 1860 x 710	300	1 x 3
B 14000 EFM	14000	104	750 x 1240 x 1420	400	2 x 2
B 21000 EFM	21000	156	750 x 1240 x 1860 750 x 1860 x 1420	600	3 x 2 2 x 3
B 28000 EFM	28000	208	750 x 1240 x 2840 750 x 2840 x 1420	800	2 x 4 4 x 2
B 31500 EFM	31500	234	750 x 1860 x 2140	900	3 x 3
B 42000 EFM	42000	312	750 x 2840 x 2840	1200	4 x 3
B 56000 EFM	56000	416	750 x 2840 x 2840	1800	4 x 4
B 63000 EFM	63000	468	750 x 3760 x 2140	2100	3 x 6
B 70000 EFM	70000	520	750 x 2840 x 2840	2500	4 x 5

If you have any further question about filter classes and types, applications, services and project-specific quotations, we are happy to support you.

Contact us by phone  
+49 (0) 9868 9826-0

Or send us an email via  
info@bristolfilter.de

## // CUSTOMIZED

- Air direction either horizontally left to right or right to left
- Adaptation of country-specific supply voltages for all filter units
- Customer-specific special designs for air inlet or filter fitting possible

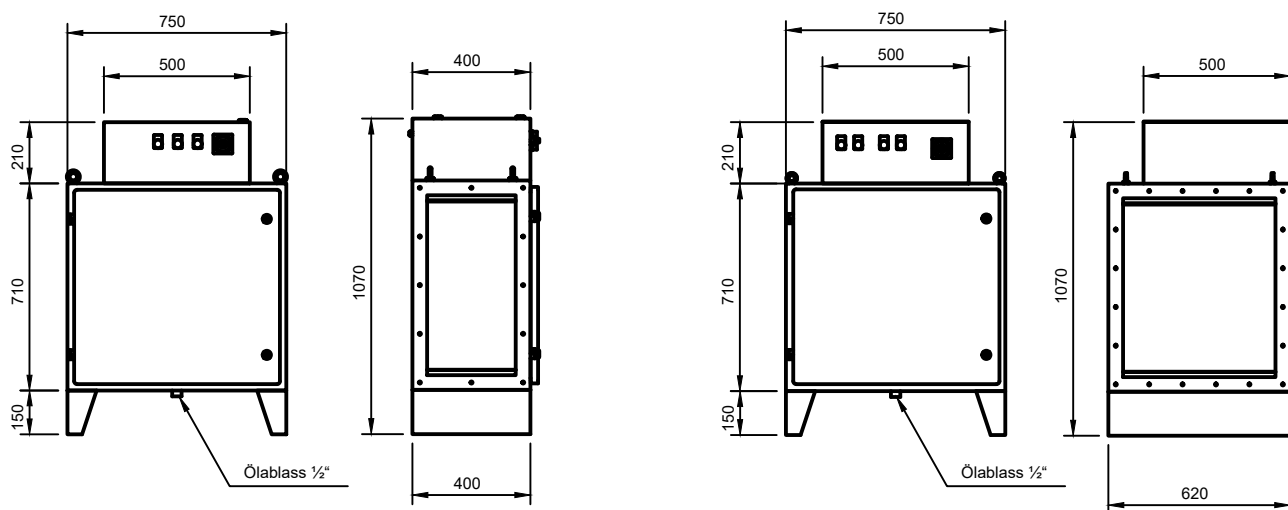

// Front and side view of a B 2200 / 3500 EF Modular Filter Unit (example)

// Electrostatic Air Filter Units - Mechanical Air Filter Units  
Complete Solutions - Cable Duct Systems - Service